

Domestic Asset Tracking Alarm System (DATAS)

USER MANUAL

Before Installation

We recommend learning the tags to the DATAS before installing the unit.
Put all tags in a metal container with a lid.
Connect the unit to the serial port of a PC and use HyperTerminal to aid in the learning process.

Configure HyperTerminal as follows:

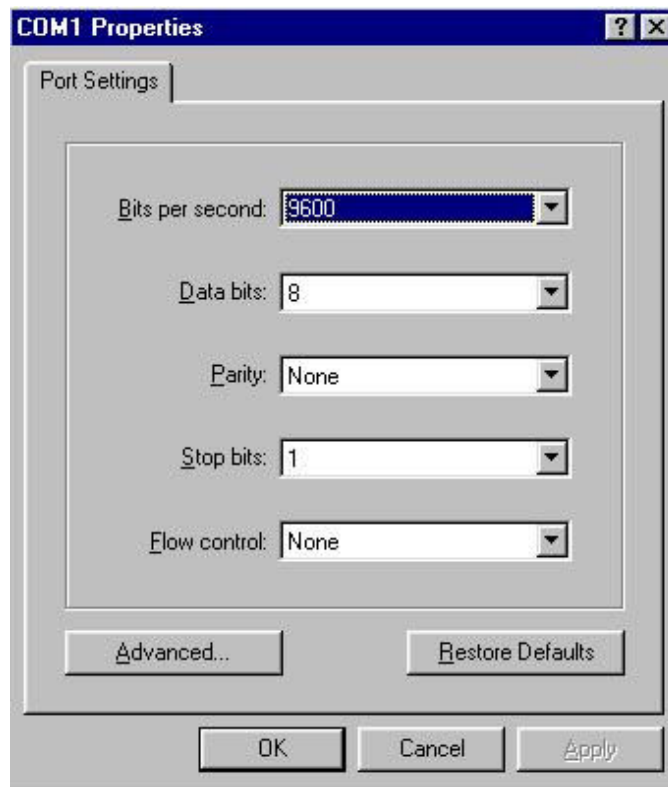

Figure 1 Com setup

Connect the DATAS unit as follows:

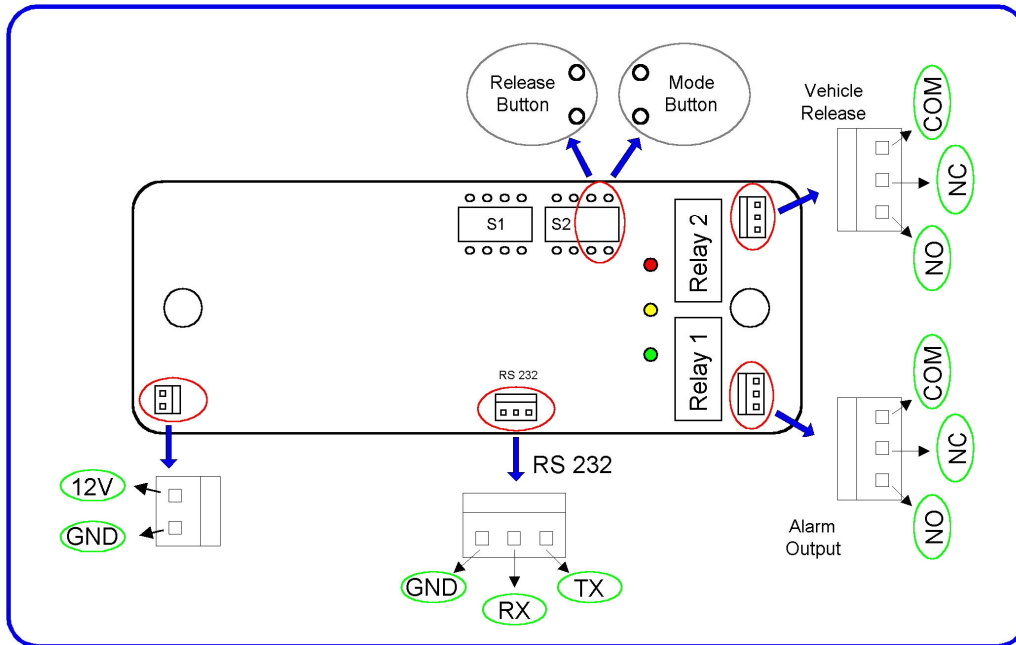

Figure 2 Connections

After power up two beeps will be heard and the following will be displayed in the HyperTerminal screen:

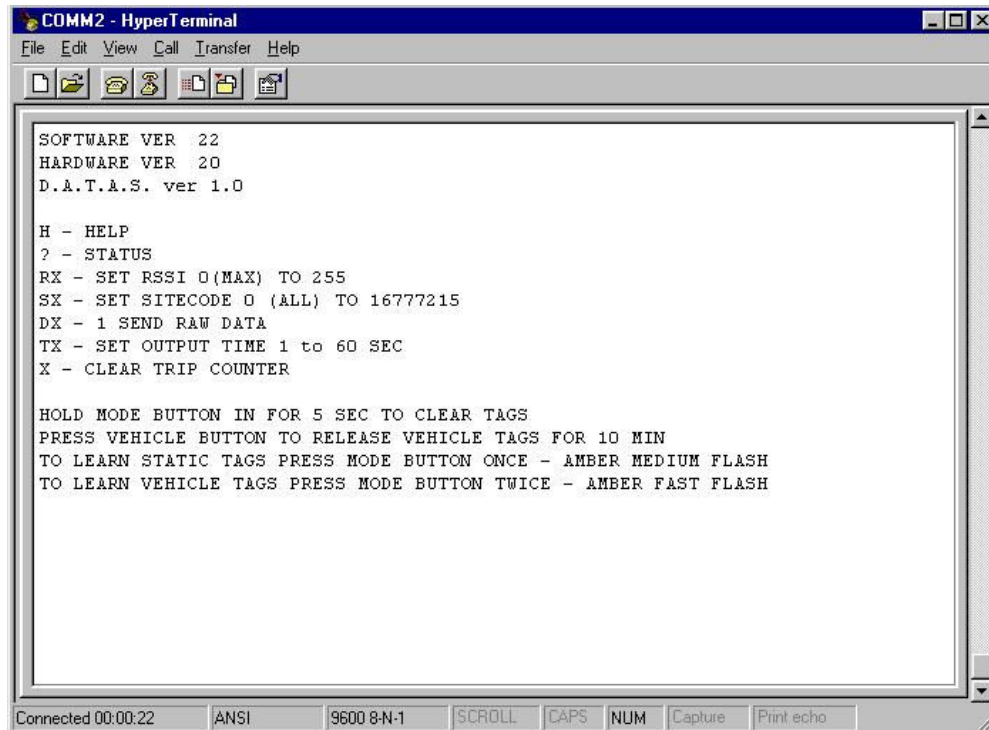

Figure 3 Version and Help display

The software and hardware versions of the Wavetrend module and the DATAS version are displayed.
The help screen is also displayed.

After 5 seconds the amber LED will start flashing slowly indicating that the DATAS is operational. If there are no tags in the database the red LED will also flash.
The default RSSI value, sitecode and output timer are also displayed.

```
RSSI: 0
SITECODE: 0
OUTPUT TIME: 2 SEC
```

Figure 4 Default configuration values

Set the sitecode for the tags by typing “s” or “S” and the sitecode followed by the “enter” key

For example “S3456” followed by the “enter” key

To confirm this, type “?” followed by the “enter” key, and the RSSI value, sitecode and alarm output duration stored in the DATAS, will be displayed.

```
S3456
OK
?

RSSI: 0
SITECODE: 3456
OUTPUT TIME: 2 SEC
```

Figure 5 Site code setup

Start learning tags to DATAS

Take one tag from the metal box, the green LED will flash every time the DATAS unit reads a tag. The following is displayed in HyperTerminal.

```
UNKNOWN TAG: 12002    RSSI: 90    AGE: 600 DAYS
UNKNOWN TAG: 12002    RSSI: 85    AGE: 600 DAYS
UNKNOWN TAG: 12002    RSSI: 85    AGE: 600 DAYS
UNKNOWN TAG: 12002    RSSI: 83    AGE: 600 DAYS
UNKNOWN TAG: 12002    RSSI: 85    AGE: 600 DAYS
```

Figure 6 Unknown tags

The tag number, RSSI value and age in days for each unknown tag read are displayed.

To add a static tag press the mode button once and to add a vehicle tag, press it twice.
Each time the mode button is pressed the buzzer will beep. When scanning for a new

static tag the amber LED will flash at a medium frequency, and fast when scanning for a vehicle tag. It will take 4 seconds before it will start scanning for new tags. The first unknown tag will be added to the static or vehicle database as selected by the mode button. If there is no new tag within 15 seconds the learn mode will timeout and return to normal mode.

```

MODE : LEARN
START SCANNING
UNKNOWN TAG: 12002   RSSI: 93   AGE: 600 DAYS
ADD TAG > 12002
MODE : NORMAL
  
```

Figure 7 Add Tag

Once a tag has been added to the database a tag summery is displayed in HyperTerminal every 5 seconds indicating the tag type, tag number, timeout counter, alarm counts and the tripped count.

```

*****
TAG STATUS SUMMERY
TAG:          12002  COUNT DOWN: 30  ALARM COUNT: 0  TRIPED: 0
VEHICLE TAG:   3010  COUNT DOWN: 29  ALARM COUNT: 0  TRIPED: 0  ACTIVE
*****
  
```

Figure 8 Summery

In the vehicle tag section the current status (active or away) of each tag is displayed.

The raw data can be seen on HyperTerminal by activating it as follows:
Type “D1” followed by the “enter” key and you will see the following:

```

READ VEHICLE TAG:  3010  RSSI: 73  REP RATE: 1.5 SEC  AGE: 609 DAYS
READ TAG:          12002  RSSI: 99  REP RATE: 1.5 SEC  AGE: 602 DAYS
READ TAG:          12002  RSSI: 99  REP RATE: 1.5 SEC  AGE: 602 DAYS
READ VEHICLE TAG:  3010  RSSI: 73  REP RATE: 1.5 SEC  AGE: 609 DAYS
READ TAG:          12002  RSSI: 99  REP RATE: 1.5 SEC  AGE: 602 DAYS
  
```

Figure 9 Raw Data

To deactivate the raw data type “D0” followed by the “enter” key.

Once all the tags are learned (up to 10 static and 3 vehicle tags) and you need to tighten the perimeter you can set the RSSI Value as follows:
Type "R0" followed by the "enter" key (Default) to give maximum read range and tighten the perimeter by increasing the RSSI value for example "R100" followed by the "enter" key. In this case any tag with a RSSI value less than 100 will be ignored.

```
r100
OK
?

RSSI:100
SITECODE:      0
OUTPUT TIME:   2 SEC
```

Figure 10 Set RSSI

The time the alarm relay (Relay 1) will pulse when a tag moves beyond the perimeter can be adjusted as follows:

For example if we want the relay to pulse for 20 seconds type "T" or "t" followed by "20" and the "enter" key and to verify, type "?" followed by the "enter" key.

```
t20
OK
?

RSSI:100
SITECODE:      0
OUTPUT TIME:   20 SEC
```

Figure 11 Set output timing

The trips (alarm events) for each tag is stored and displayed in the summary. To clear all the trips type "X" or "x" followed by the "enter" key.

Installation.

Install the DATAS in the center of the house and place the tags in the intended positions. Through the GUI in HyperTerminal make sure that all the tags have a RSSI value greater than 50, if not, move the tag or the antenna to achieve it.

Cable the vehicle release button and away light cable to the appropriate location.

Connect Relay 1 (Normally, Common and NC) in series to the 24 Hour zone of the alarm panel or any other peripheral.

Connect Relay 2 to the away light indicating that the vehicle tags are released from the system.

The red LED on the DATAS will indicate that an alarm condition occurred. The tag summary in HyperTerminal will indicate the tag removed from the perimeter.

To clear the alarm condition, press the mode button once. (No Beep).

Operation.

To release a vehicle tag from DATAS, press the vehicle release button. All vehicle tags are released for 10 minutes. Relay 2 energizes for as long as the vehicles are released. It can be used for a visible indication.

```
DISABLE VEHICLES
*****
TAG STATUS SUMMERY
*****
TAG:          12002  COUNT DOWN: 30  ALARM COUNT: 0  TRIPED: 0
VEHICLE TAG:  3010  COUNT DOWN: 30  ALARM COUNT: 0  TRIPED: 0  AWAY
VEHICLE TAGS AWAY FOR 10 MINUTES
*****
```

Figure 12 Release Vehicle tags

Once the 10 minutes expired all remaining vehicle tags are automatically activated. The active and away vehicle tags are displayed in the tag summery in HyperTerminal. When a vehicle tag returns to the perimeter it is automatically activated again.