

# MONITORMATE

## ROYAL ACCESS CONTROL

Advantech's Adam-6051 Ethernet-based unit

## USER'S MANUAL

INDEX	PAGE
1. Introduction	2
2. ADAM-6051 Specifications	3
2.1 Technical Specifications	3
2.2 LED Status	4
2.3 Wiring and Connections	5
3. ADAM-6051 Utility Software	7
3.1 Installing the Utility Software	7
3.2 How to use the ADAM-5000/6000 Utility	7
3.3 Configuring your ADAM-6051 unit	9
4. MonitorMate Software	10
4.1 Installing MonitorMate Software	10
4.2 MonitorMate Basic Use	11
4.2.1 Components on the MAIN Operation Screen	11
4.2.2 Managing Inputs/Outputs on the MAIN Operation Screen	12
4.2.3 Events	14
4.3 MonitorMate Administration	14
4.3.1 MAIN Operation Screen	14
4.3.2 Adding and Deleting Maps	16
4.3.3 Adding, Deleting and Editing Units	17
4.3.4 Adding Inputs on the Map	20
4.3.5 Adding Outputs on the Map	21
4.3.6 Editing Inputs/Outputs on the Map	24
4.3.7 Deleting Inputs/Outputs from the Map	24

# 1. Introduction

MonitorMate is a cost-effective, distributed monitoring and control solution using Advantech's ADAM-6051 Ethernet-based unit. The ADAM-6051 is based on the popular Ethernet networking standards used today in most business environments. The ADAM-6051 retrieves I/O values from sensors and publishes these real-time I/O values to networking nodes on the Local Area Network.

Maps/Floorplans are imported and I/O's are represented on the map. Input values are used for door, alarm, fire alarm etc. status monitoring. Outputs are used for arming/disarming alarm panels, toggling switches etc.

A brief view of the system architecture.

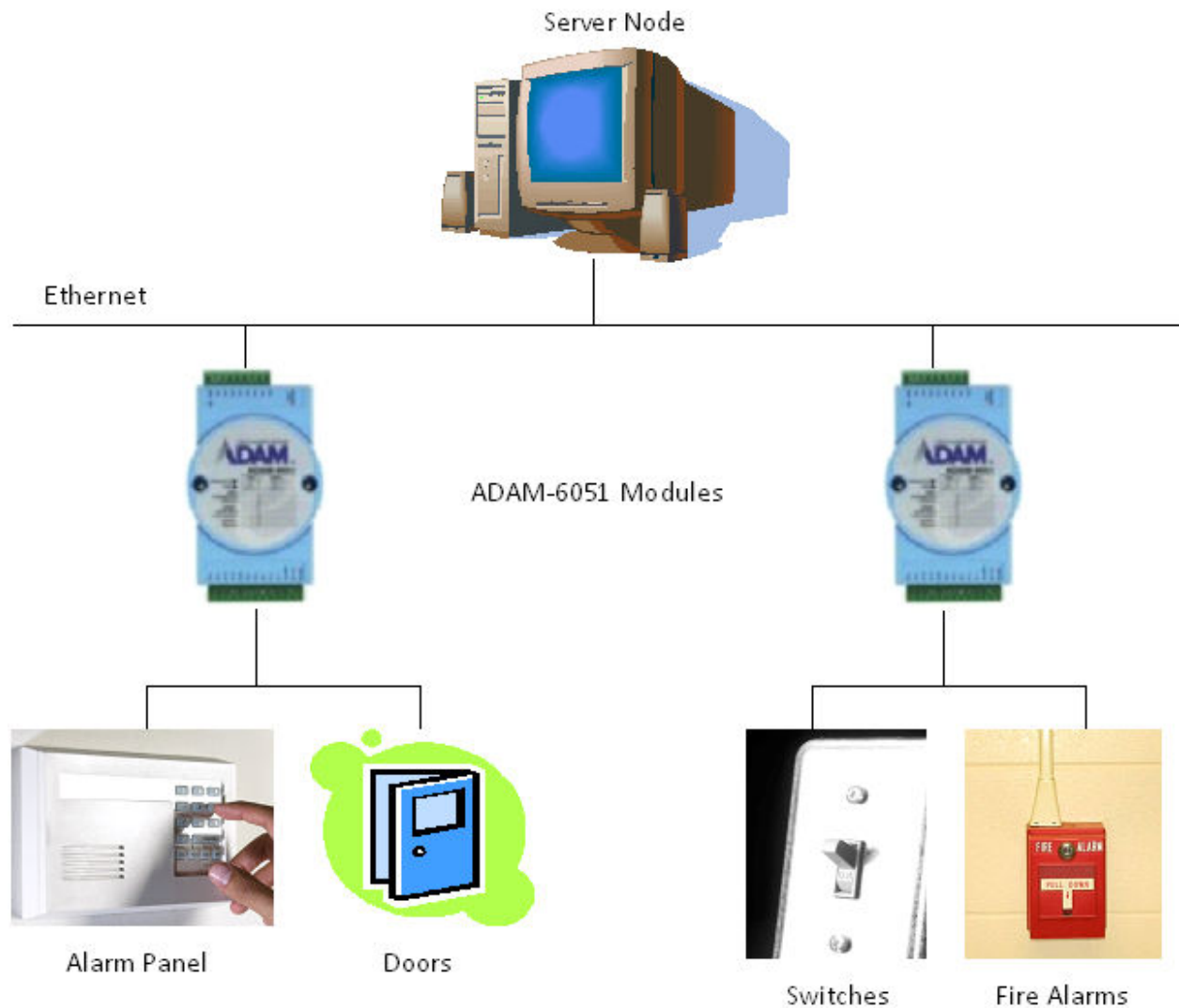

## **2. ADAM-6051 Specifications**

### **2.1 Technical Specifications**

- **Ethernet:** 10 BASE-T IEEE 802.3  
100 BASE-TX IEEE 802.3u
- **Wiring:** UTP, category 5 or greater
- **Bus Connection:** RJ45 modular jack
- **Comm. Protocol:** Modbus/TCP on TCP/IP and UDP
- **Data Transfer Rate:** Up to 100 Mbps
- **Unregulated 10-30 V DC**
- **Status Indicator:** Power, CPU, Communication (Link, Collide, 10/100 Mbps, Tx, Rx)
- **Channel:** 16
- **I/O Type:** 12 DI / 2 DO / 2 Counter
- **Digital Input:** Dry Contact  
Logic Level 0: Close to GND  
Logic Level 1: Open  
(Logic level status can be inverted by Utility)
- **Digital Output:** Open Collector to 30 V
- **Power Consumption:** 2 W (Typical)



## 2.3 Wiring and Connections

### Power supply wiring

Although the ADAM-6051 systems are designed for a standard industrial unregulated 24 V DC power supply, they accept any power unit that supplies within the range of +10 to +30 V DC. The power supply ripple must be limited to 200mV peak-to-peak, and the immediate ripple voltage should be maintained between +10 and +30 V DC. Screw terminals +Vs and GND are for power supply wiring.

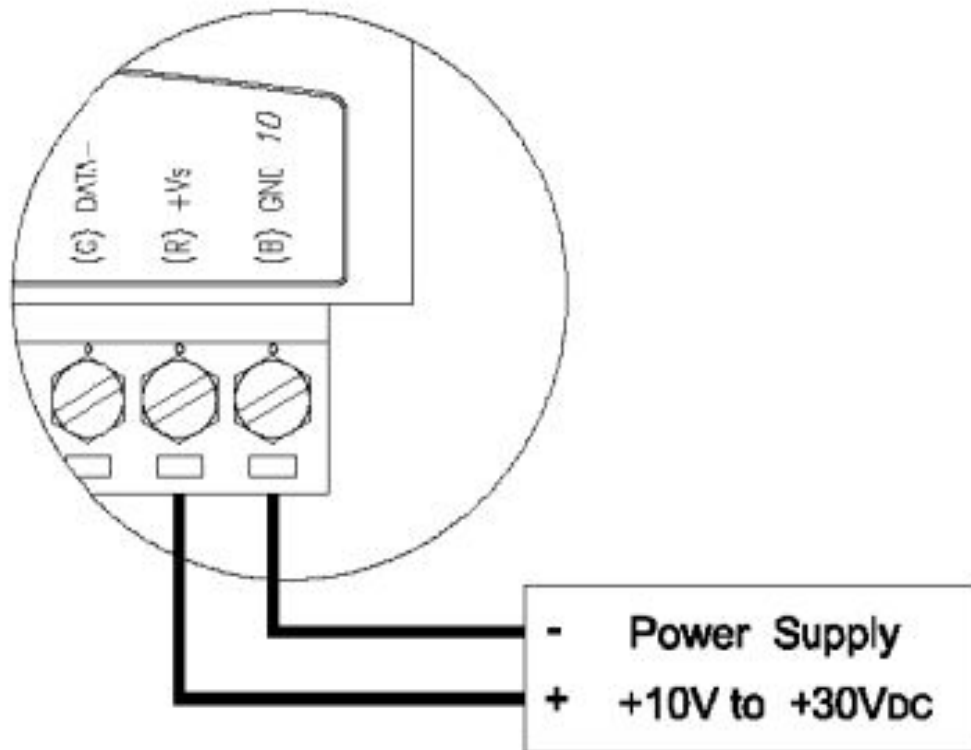

### Digital Input Wiring

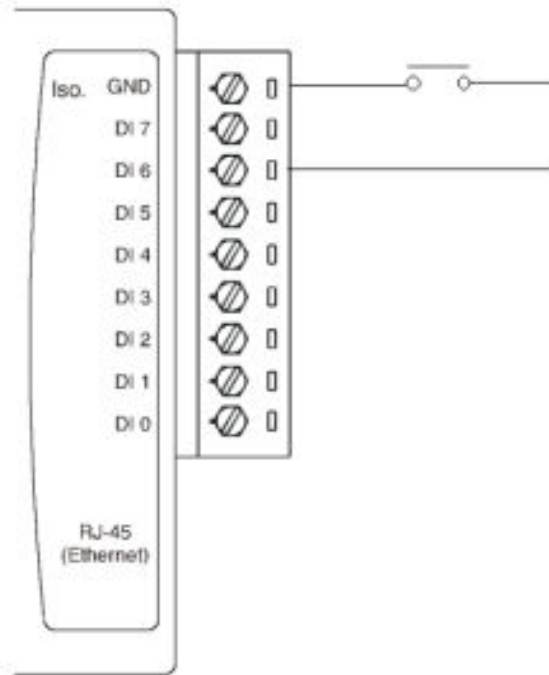

**Digital Output Wiring**

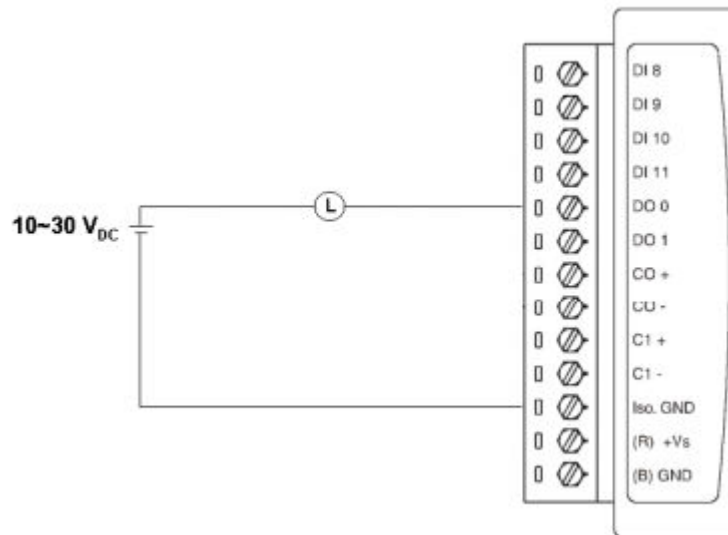

**3. ADAM-6051 Utility Software**

The Utility software offer a graphical interface that helps you configure the ADAM-6051 modules. It is also very convenient to test and monitor your Remote System. The following guidelines will give you some brief instructions on how to use the Utility.

**\*Note that not ALL the Utility's functions are covered in this manual, but only those necessary to configure the ADAM-6051 units that are being used in the MonitorMate application.**

### **3.1 Installing the Utility Software**

- Insert the Advantech Automation mini-cd (provided with every module) into the CD/DVD-ROM
- If Autoplay doesn't start, click Start, Run and type CD/DVD-Drive (default D:)\setup.exe
- Install Products
- ADAM-5000/6000 TCP Utility
- Exit

### **3.2 Guidelines and Instructions on How to use the Utility**

#### **Main-Menu**

Double click the icon of ADAM-5000/6000 Ethernet Utility shortcut.

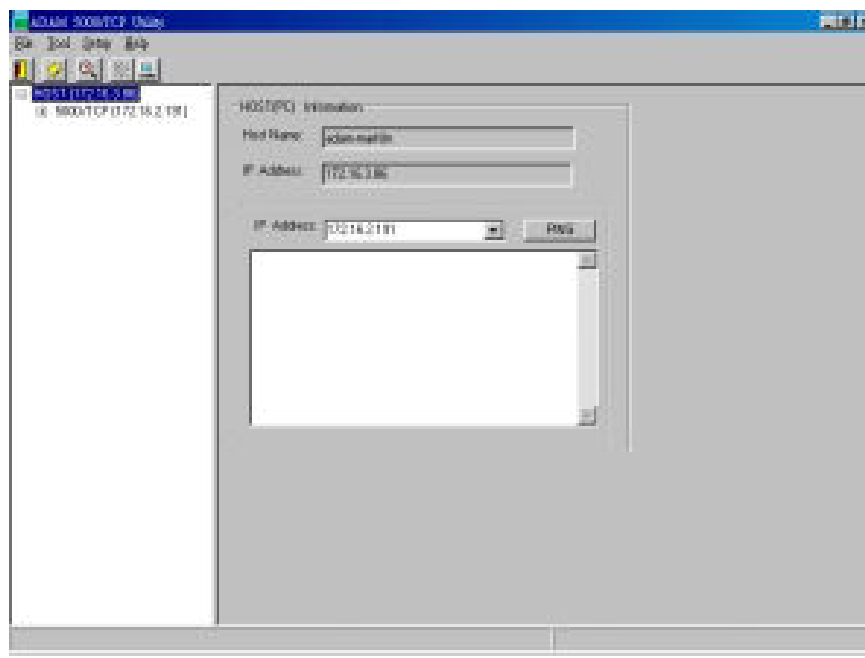

The top of the operation screen consists of a function menu and a tool bar for user's commonly operation functions.

### Item File



Exit function to exit this Utility Program.

### Item Tool

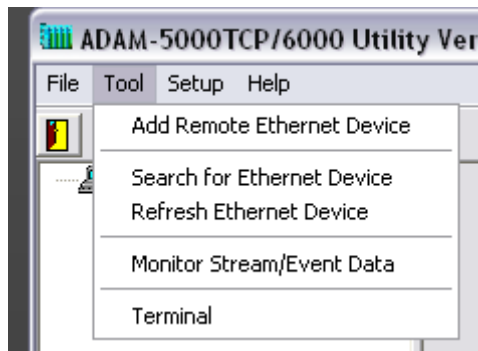

**Add Remote Ethernet Device** : Create a new ADAM-6051 module located in other Ethernet domination, available to local LAN application.

**Search for Ethernet Device** : Search all units in the specific Ethernet domination. (The same with hist PC's Ethernet domination)

**Refresh Ethernet Device** : Refresh the specific unit to verify the system status.

**Terminal** : Call up the operation screen of Terminal emulation to do the request/response command execution.

### Item Setup



Timeout and Scanrate setting function for each unit.

### Toolbar

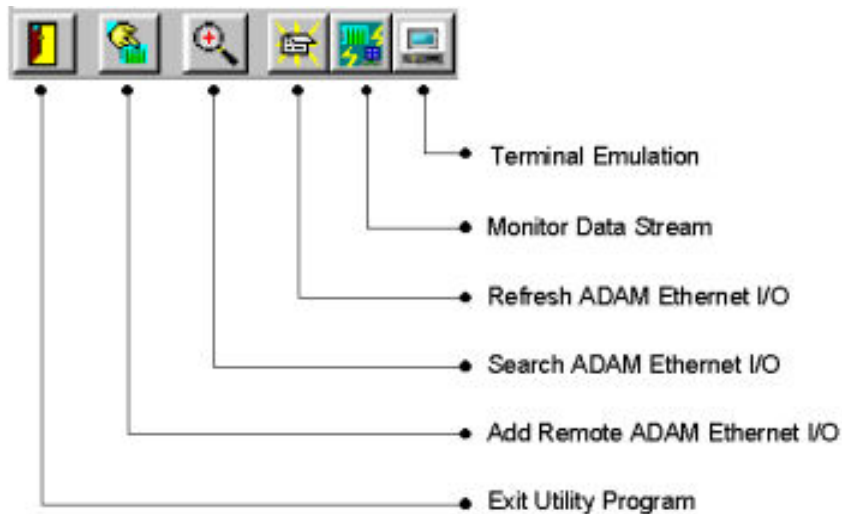

## **3.3 Configuring your ADAM-6051 unit**

After the application started, it will automatically search for units in the same Ethernet domination as your Host PC.

If any units have been found, the tree-structure display will be populated with all the units in the same range.

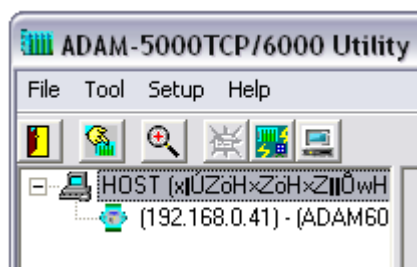

To configure a unit with a specific IP Address, click on the address displayed in the tree-structure.

Then click on the Network tab.

Configure the desired IP Address for the unit, and Subnet Mask the same as your Host PC.

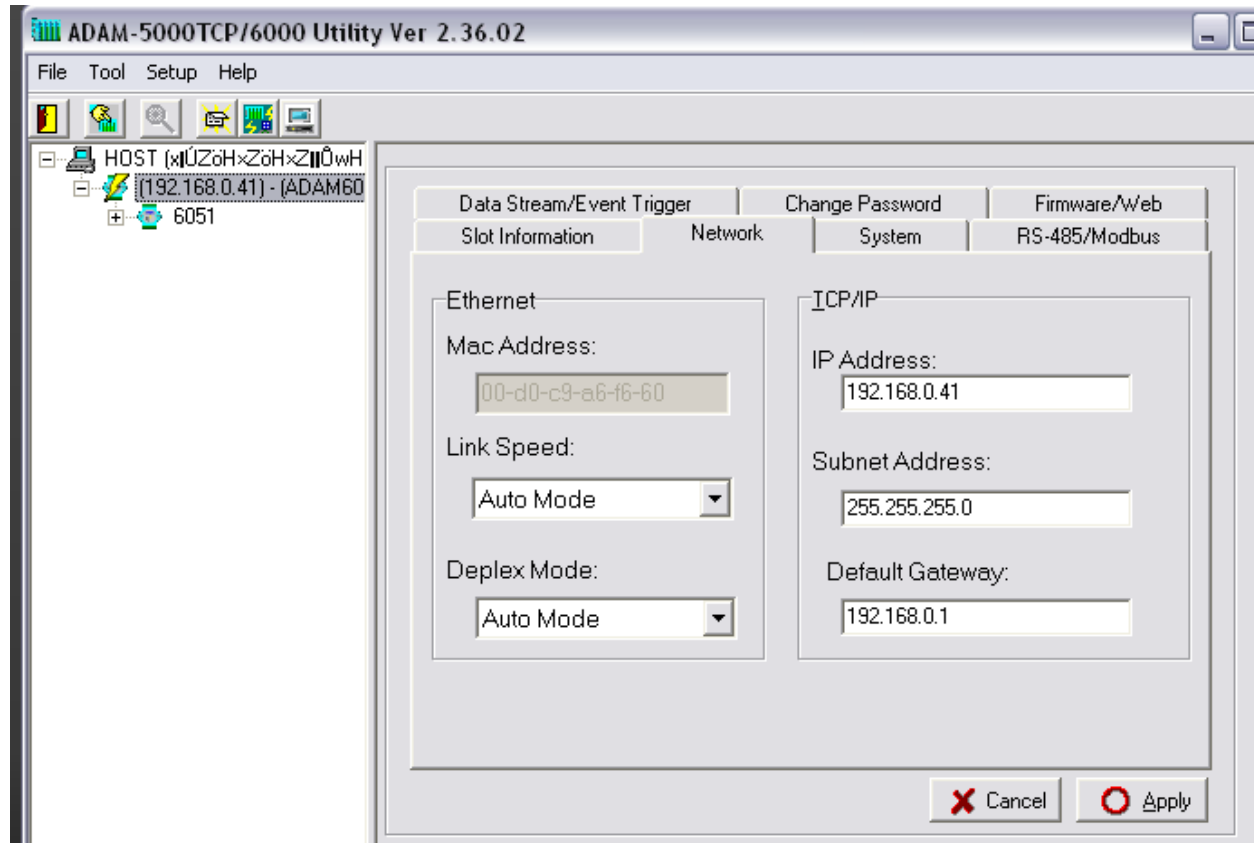

Click Apply

Default password : 00000000 ( 8 x 0's)

On prompt, click YES.

Close the Utility software.

## **4. MonitorMate Software**

### **4.1 Installing MonitorMate Software**

- Double click on the Alarm.msi icon.
- Click Next.
- Specify an installation path. Recommended to use the default path.
- Click Next x 2.
- After successful installation, click Close.
- Restart the Host PC.

## 4.2 MonitorMate Basic Use

### 4.2.1 Components on the MAIN Operation Screen

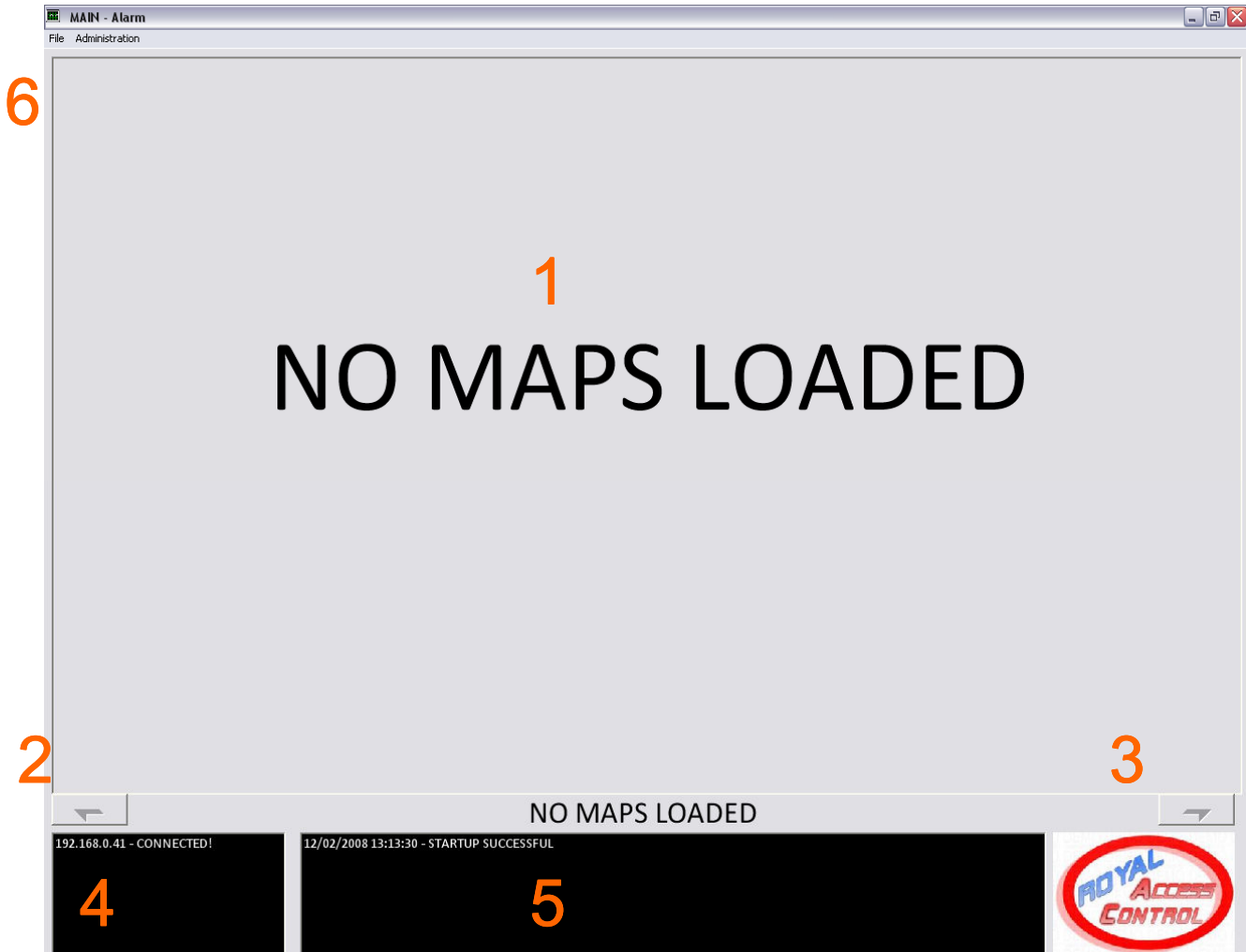

1. **MAP** – Showing your current map.
2. **PREVIOUS MAP** – Moving to the previous map (if any).
3. **NEXt MAP** – Moving to the next map (if any).
4. **UNITS LIST** – Listing all the defined units and their connection status.
5. **EVENT LIST** – Listing all the events eg. Alarm and Door Triggers etc.
6. **MENU** – Menu for Application Administration.

## 4.2.2 Managing Inputs / Outputs on the MAIN Operation Screen

### Inputs

- The state of your inputs are indicated as follows
  - CLOSED State

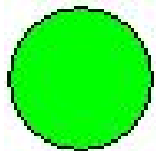

- OPENED State

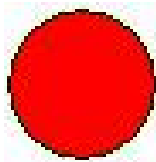

### Outputs

- **TOGGLE / PMRB Outputs**
  - Both these outputs operates the same way
  - OFF State

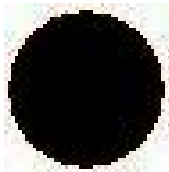

- ON State

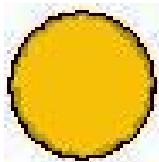

- Clicking on the image will toggle the output state.

- **ALARM Outputs**

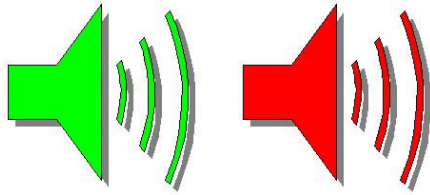

- Click on the Alarm image

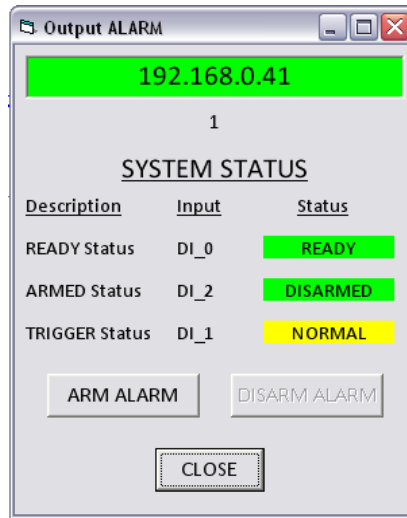

- This Alarm Operation Screen indicates the connection status, the input values predefined with the READY, ARMED and TRIGGER feedback lines of the alarm panel.
- Successful connection will be indicated by a GREEN IP Address, else with a RED IP Address
- If the Alarm system is in a READY and DISARMED state, you will be able to ARM the panel remotely.
- If the Alarm system was TRIGGERED, you will be able to silence the Alarm system remotely, but acknowledgement on the panel still needs to be done manually before the panel can be ARMED again.

## 4.2.3 Events

- Double-clicking on the event list will indicate on the map where the event occurred.

```
12/02/2008 13:49:54 - STARTUP SUCCESSFUL
12/02/2008 13:50:12 - 192.168.0.41 - 0 - Map Ex - DI_0 - 192.168.0.41 - DO_0 - READY STATUS - OPENED
12/02/2008 13:50:13 - 192.168.0.41 - 1 - Map Ex - DO_0 - 1 - ALARM TRIGGERED
12/02/2008 13:50:13 - 192.168.0.41 - 0 - Map Ex - DI_2 - 192.168.0.41 - DO_0 - ARMED STATUS - OPENED
12/02/2008 13:50:14 - 192.168.0.41 - 0 - Map Ex - DI_0 - 192.168.0.41 - DO_0 - READY STATUS - OPENED
12/02/2008 13:50:14 - 192.168.0.41 - 1 - Map Ex - DO_0 - 1 - ALARM TRIGGERED
12/02/2008 13:50:14 - 192.168.0.41 - 0 - Map Ex - DI_2 - 192.168.0.41 - DO_0 - ARMED STATUS - OPENED
```



## 4.3 MonitorMate Administration

### 4.3.1 MAIN Operation Screen



On the first start of the application, no maps or units will be defined. "NO MAPS LOADED" will blink on the main screen.

The application also starts up in a "LOCKED MODE" for non-administrative users. To configure anything in the application, the systems needs to be unlocked.

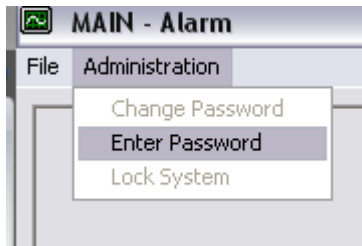

Entering the administration password will unlock the system. The default password is "MonitorMate".

**\*Note that the password is case-sensitive**

**\*It is recommended that an administrative-user change the password on first use.**

After configuration of maps and units, the system can then be locked.



### **Item FILE**

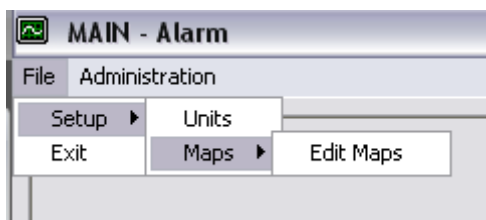

**SETUP :** To configure ADAM-6051 units and Maps to be displayed.

**EXIT :** To exit the MonitorMate application.

### 4.3.2 Adding and Deleting Maps

In UNLOCKED MODE, click on FILE, SETUP, MAPS, EDIT MAPS.

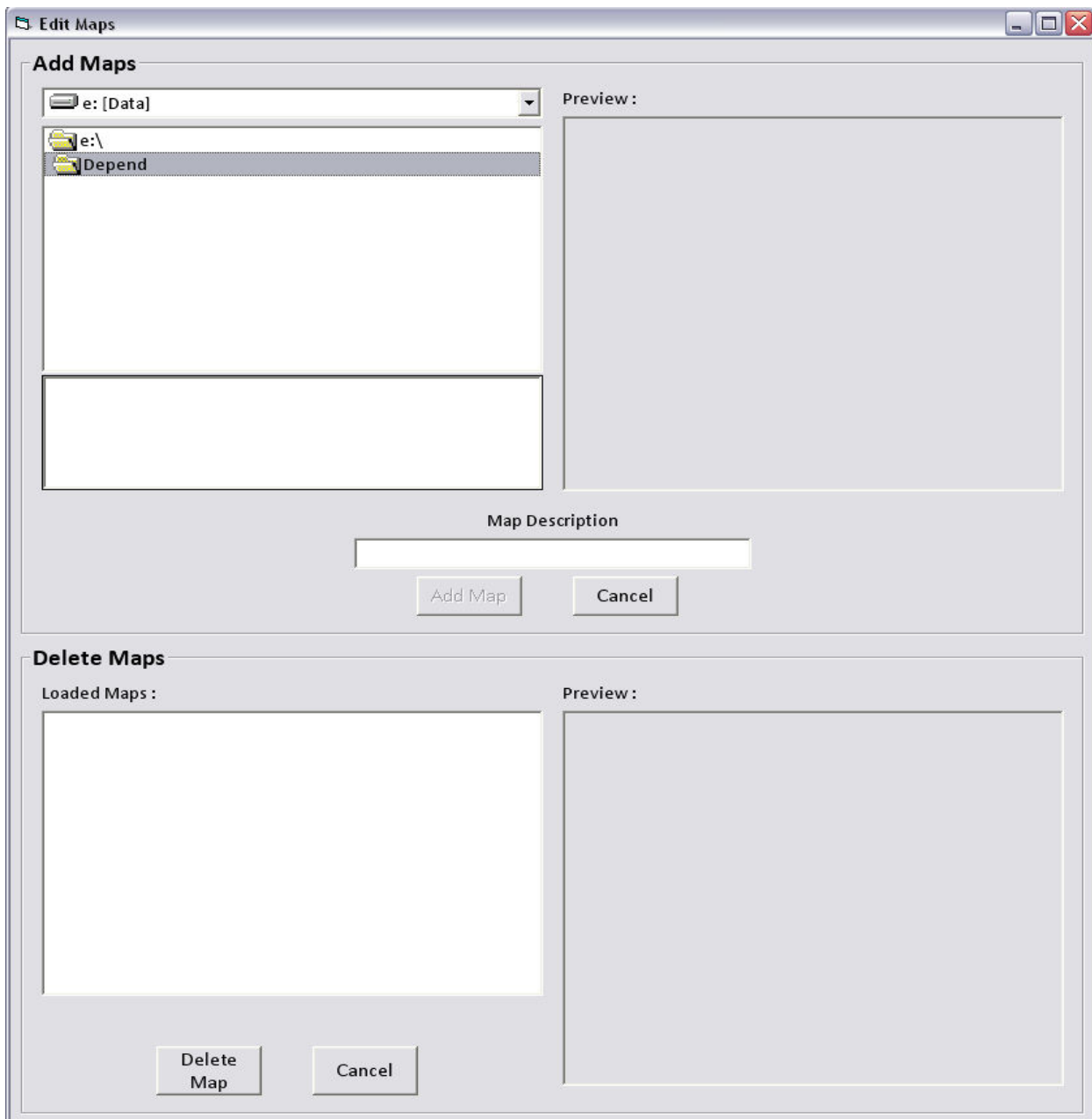

The top half of this operation screen is for adding maps to your application, where the bottom half is for deleting maps from your application.

To add a map, browse for your desired file.

**\*NOTE THAT MULTIPLE MAPS CAN BE ADDED**

**\*ONLY \*.JPG and \*.BMP SUPPORTED**

After selection, give your map a description and click add. Click YES on confirmation.

To delete a map, click on your map in the list view below and confirm your selection indicated by the preview. Click delete and YES on confirmation.

### **4.3.3 Adding, Deleting and Editing Units**

In UNLOCKED MODE, click on FILE, SETUP, UNITS.

**\*NOTE THAT A MAXIMUM OF 10 UNITS CAN BE CONTROLLED**

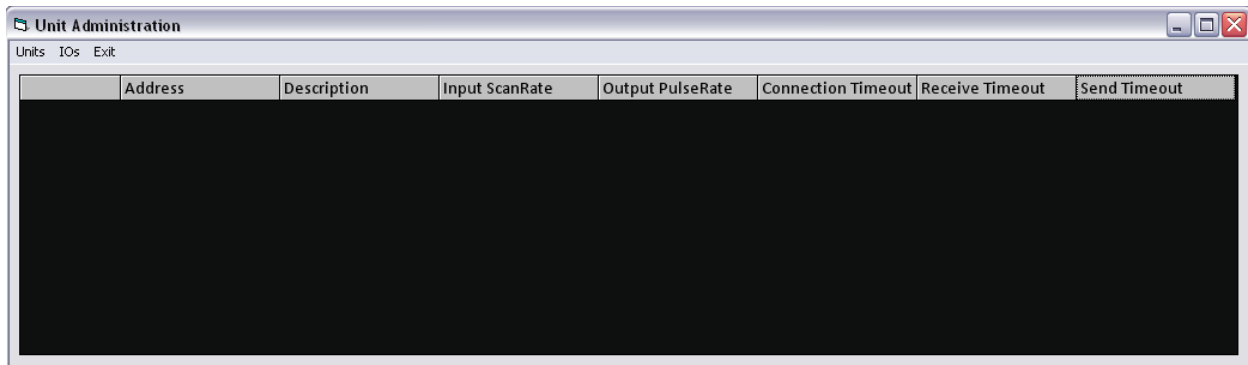

The Unit Administration Function menu consists of the following.

#### **Item UNITS**

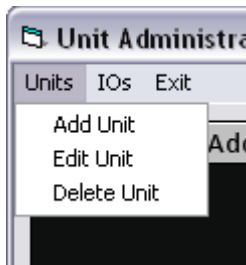

**ADD UNIT :** Add a unit to your monitoring application

**EDIT UNIT :** Edit a specific unit's data.

**DELETE UNIT :** Delete a unit from your monitoring application

#### **Item IOs**

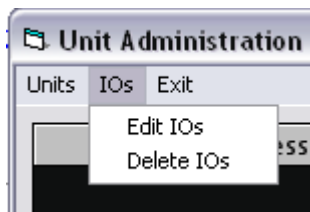

**EDIT IOs :** Edit the Inputs/Outputs of a specific unit

**DELETE IOs :** Delete Inputs/Outputs from a specific unit.

**EXIT :** To exit the Unit Administration Operation Screen.

## Adding Units

Click on UNITS, ADD UNIT.

**IP ADDRESS :** IP Address of unit. **\*MUST BE THE SAME AS IP ADDRESS DEFINED IN THE UTILITY SOFTWARE**

**DESCRIPTION :** User description for your unit for easy identification.

**INPUT SCAN RATE :** Rate (in milliseconds) at which the unit will scan for changes of the I/O values.

**OUTPUT PULSE RATE :** Length (in milliseconds) of the pulse on your defined output.

**CONNECTION, SEND, RECEIVE TIMEOUT :** The time (in milliseconds) the unit will take if no response were given.

After unit was added successfully.

	Address	Description	Input ScanRate	Output PulseRate	Connection Timeout	Receive Timeout	Send Timeout
1	192.168.0.41	Unit Example 1	1000	1000	2000	2000	2000

## Deleting Units

Click on the specific unit that you want to delete from your application.

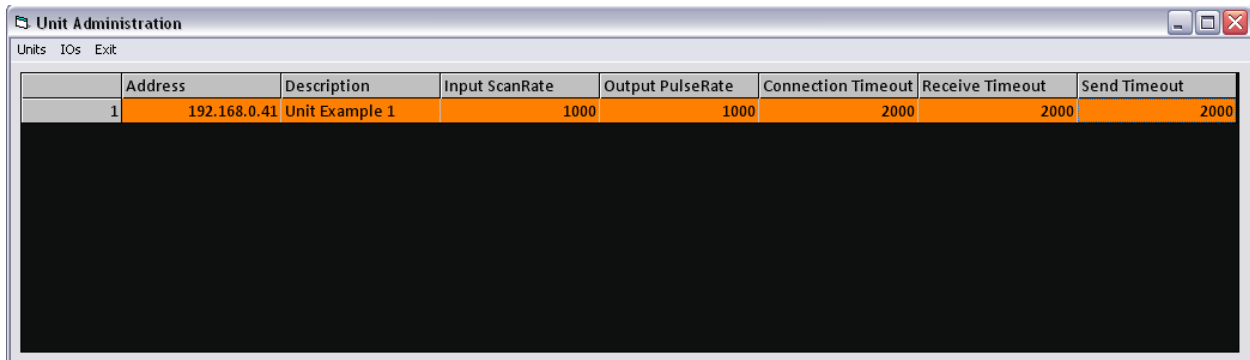

Click on UNITS, DELETE UNIT, and YES on confirmation.

## Editing Units

Click on the specific unit that you want to edit.

Click on UNITS, EDIT UNIT

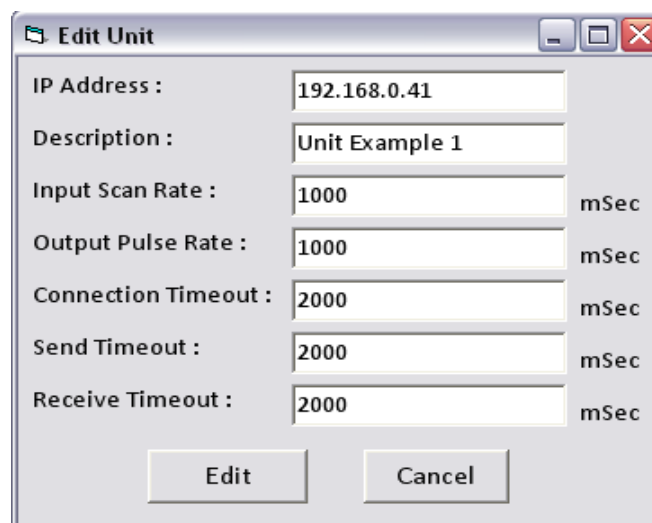

Change the desired fields of your unit and click EDIT and YES on confirmation.

### 4.3.4 Adding Inputs on the Map

\*Ensure that you have a ADAM-6051 unit and Map added to your application.

Ensure that you are in the MAIN Operation Screen.

Right-click on the map on your desired location for the input.

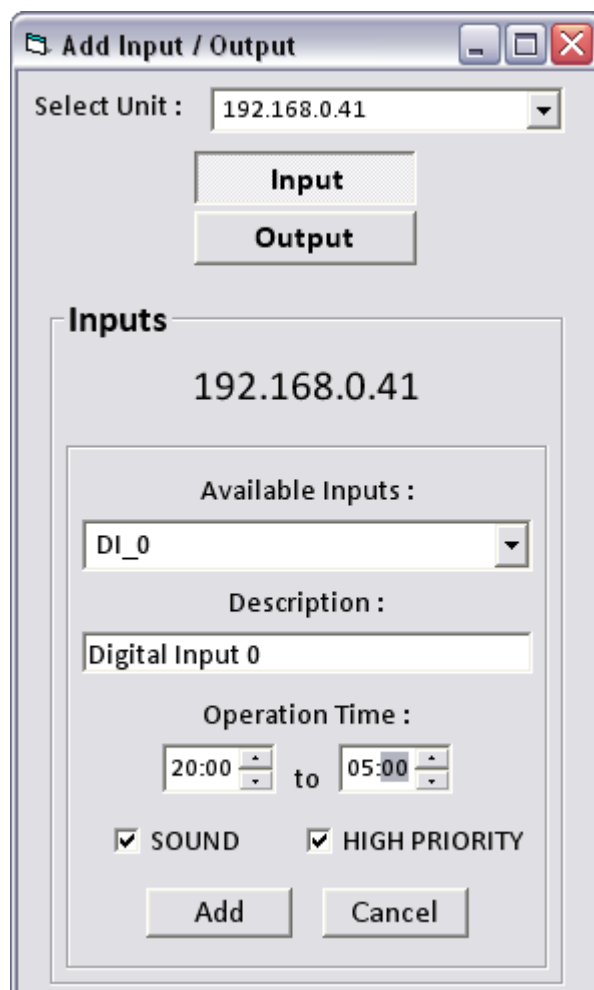

- Select one of your defined units.
- Click INPUT
- Select an Available Input on the unit (**\*Ensure that the selected input corresponds to your hardware connected input**)
- Give your input a description
- Select your time constraints in which the unit must scan your input.
- **SOUND** : If selected, the Host PC will play a sound if the input in OPENED
- **HIGH PRIORITY** : If selected, and the selected input OPENS, the MAIN Operation Screen will load the specific map on which the input was defined.

- Click ADD and YES on confirmation

After the input was added, it will show on your current map.

### **4.3.5 Adding Outputs on the Map**

**\*Ensure that you have a ADAM-6051 unit and Map added to your application.**

Ensure that you are in the MAIN Operation Screen.

Right-click on the map on your desired location for the output.

- Select one of your defined units.
- Click OUTPUT

#### **THERE ARE 3 DIFFERENT TYPES OF OUTPUTS**

- **TOGGLE OUTPUT**

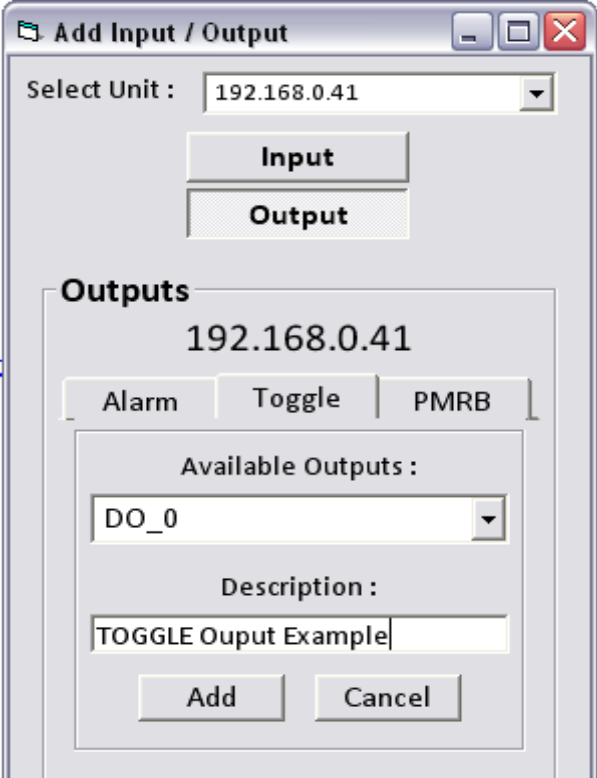

The screenshot shows a dialog box titled "Add Input / Output". At the top, there is a "Select Unit:" dropdown menu with "192.168.0.41" selected. Below this are two buttons: "Input" and "Output", with "Output" being the active selection. The main section is titled "Outputs" and contains the IP address "192.168.0.41". Underneath are three tabs: "Alarm", "Toggle", and "PMRB", with "Toggle" selected. Below the tabs is a section labeled "Available Outputs:" with a dropdown menu showing "DO\_0". Underneath that is a "Description:" field containing the text "TOGGLE Ouput Example". At the bottom of the dialog are two buttons: "Add" and "Cancel".

- **DESCRIPTION :** Toggle Output is outputs used for your basic functionality eg Light Switches, Basic Alarm Panels etc. This Output will toggle between a digital 0 and 1 depending on the output's previous state.
- Select an Available Output.
- Give your TOGGLE output a description.

- Click ADD and YES on confirmation.
- The TOGGLE output will be added onto your map, and will toggle everytime the user clicks on the output's image.

- **PMRB OUTPUT (Push Button)**

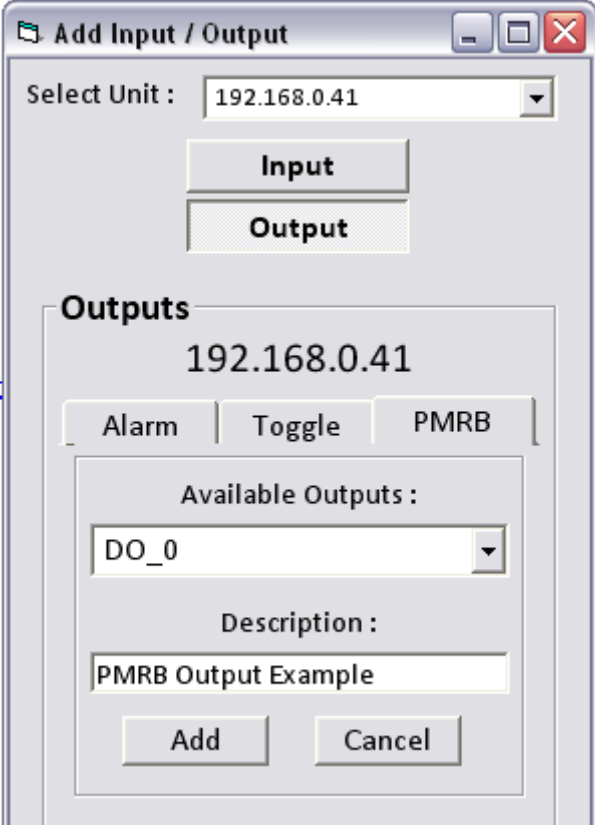

The screenshot shows a window titled "Add Input / Output". At the top, there is a "Select Unit" dropdown menu with "192.168.0.41" selected. Below this are two buttons: "Input" and "Output". The "Output" button is highlighted. Underneath, there is a section titled "Outputs" with the IP address "192.168.0.41" displayed. Below the IP address are three tabs: "Alarm", "Toggle", and "PMRB". The "PMRB" tab is selected. Under the "PMRB" tab, there is a sub-section titled "Available Outputs" with a dropdown menu showing "DO\_0". Below this is a "Description" field containing the text "PMRB Output Example". At the bottom of the "PMRB" section are two buttons: "Add" and "Cancel".

- **DESCRIPTION** : PMRB Outputs is outputs used for your basic functionality. This output will send a digital 1 if the user clicks on the output's image and send a digital 0 whenever the user releases the click on the output's image.
- Select an Available Output.
- Give your PMRB output a description.
- Click ADD and YES on confirmation.
- The PMRB output will be added onto your map.

- **ALARM OUTPUT**

The screenshot shows a software dialog box titled "Add Input / Output". At the top, there is a "Select Unit" dropdown menu with "192.168.0.41" selected. Below this are two buttons: "Input" and "Output", with "Output" being the active one. The main section is titled "Outputs" and displays the IP address "192.168.0.41". There are three tabs: "Alarm", "Toggle", and "PMRB", with "Alarm" selected. Under the "Available Outputs" section, a dropdown menu shows "DO\_0" selected. Below that, there are three input selection fields: "Input used for READY STATUS" with "DI\_11" selected, "Input used for ARMED STATUS" with "DI\_10" selected, and "Input used for TRIGGER STATUS" with "DI\_9" selected. A "Description" field contains the text "ALARM Output Example". At the bottom of the dialog are "Add" and "Cancel" buttons.

- **DESCRIPTION** : ALARM Outputs are used for Alarm panels with a 3-line feedback indicating the Alarm panel's READY, ARMED and TRIGGER status.
  - **READY** : Indicating that the Alarm is ready and can be ARMED.
  - **ARMED** : Indicating that is Alarm is ARMED/DISARMED.
  - **TRIGGER** : Indicating that the Alarm TRIGGERED.
- Select an Available Output.
- Select an Available Input that will indicate the Alarm's READY Status.
- Select an Available Input that will indicate the Alarm's ARMED Status.

- Select an Available Input that will indicate the Alarm's TRIGGERED Status.
- Give your ALARM output a description.
- Click ADD and YES on confirmation.

### 4.3.6 Editing Inputs/Ouputs on a Map

**\*NOTE THAT INPUTS/OUTPUTS MUST FIRST BE ADDED ONTO A MAP TO EDIT THEM IN THE ADMINISTRATION OPERATION SCREEN**

- In the MAIN Operation Screen, click FILE, SETUP and UNITS
- In the Unit Administration Operation Screen, select a unit and click IOs, EDIT IOs.

#### INPUTS

Inputs				
	Input Description	Scan Time	Sound Alarm	High Priority
DI_0	Input Example	20:00 to 05:00	<input checked="" type="checkbox"/>	<input checked="" type="checkbox"/>
DI_1		00:00 to 23:59	<input type="checkbox"/>	<input type="checkbox"/>

- Fields that can be edited : Description, ScanTime, Sound, High Priority

#### OUTPUTS

Outputs		
	Output Description	Alarm Status
DO_0	Output Example	N/A
DO_1		N/A

- Fields that can be edited : Description
- After edit, click SUBMIT and YES on confirmation

### 4.3.7 Deleting Inputs/Ouputs from a Map

- In the MAIN Operation Screen, click FILE, SETUP and UNITS
- In the Unit Administration Operation Screen, select a unit and click IOs, DELETE IOs.
- Select the specific input or output to delete from the map.
- Click DELETE and YES on confirmation.